

使用说明书

User Guide

工业缝纫机

Industrial sewing machine

感谢您购买本公司的产品。



为了您的使用安全，请您在使用之前一定仔细阅读本使用说明书。

Thank you for purchasing our products.

For your use safety, please must read the instruction manual before use.

USER MANUAL FOR AUTOMATIC HIGH-SPEED SEWING SYSTEM

ATTENTION

- 1) Please make sure that you have read the user manual and enclosed sewing machine instruction before operating the machine.
- 2) The product is only for applicable for sewing machine which is in the specified range. Do not use it for other purposes.
- 3) The product must be debugged or operated by the professional person who has been trained.
- 4) The sign  means safety warn, user must take care and obey it strictly. Otherwise it will cause personal injury or machine damage.
- 5) The sign  means the safety warn about the high-voltage and electronic. User must take care and obey it strictly. Otherwise it will cause personal injury or machine damage.
- 6) When connecting the power, make sure that it is conformed to the voltage and the technical requirements marked on the label, and the product connect the ground.
- 7) It's a precision electronic product .Please don't use when thundering or the voltage is not steady or the poor contact. It may cause the machine damage.
- 8) Don't step the pedals when the power is being connected.
- 9) Please keep far away from the place where has high frequency electromagnetic wave and radio transmitter when operating the machine, otherwise it will cause false action.
- 10) The product operating temperature requirement:
 - a、 Please operate the machine in the temperature between 5℃ and 45 ℃
 - b、 Please don't operate the machine in the direct sunlight or outdoor
 - c、 Don't operate the machine beside the heater(electric heater)
 - d、 Keep the working place's relative humidity in 30%~95%
 - e、 Please don't operate the machine beside the combustibile gas or the explosive
- 11) The power must be cut off when doing the following operations:
 - Installation machine
 - Opening the control box and pulling out and inserting any plug from the control box
 - Opening the machine head, changing the needle or threading the needle
 - Thundering ,the machine stops working or not used for a long time, being mended or adjust
- 12) Restarting the machine ,the interval must be longer than 30 seconds.
- 13) It must be set and mended by professional person.
- 14) All spare-parts for mending must be supplied by our company or confirmed by our company before using.
- 15) Please do not percussion or bumping products and devices with inappropriate objects.

1、Product installation

1.1 Product specification

Model	High-speed sewing machine	Power voltage	AC220V/AC110V
Power frequency	50Hz/60Hz	Maximum output power	550W

1.2 Connector interface specification

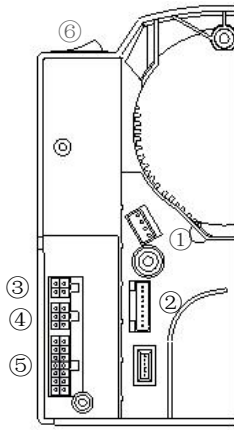

- ① Motor socket ② Motor encoder socket ③ Pedal switch socket ④ LED light/ Backstitch switch / Compensate needles switch/ Oil induction ⑤ Electromagnet socket ⑥ Power socket

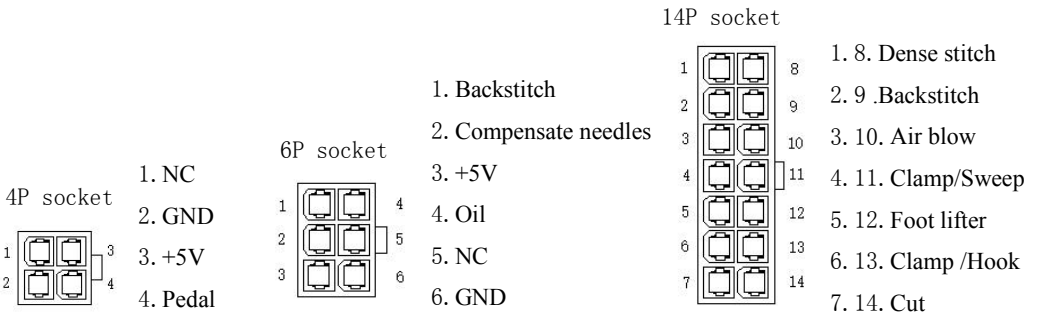





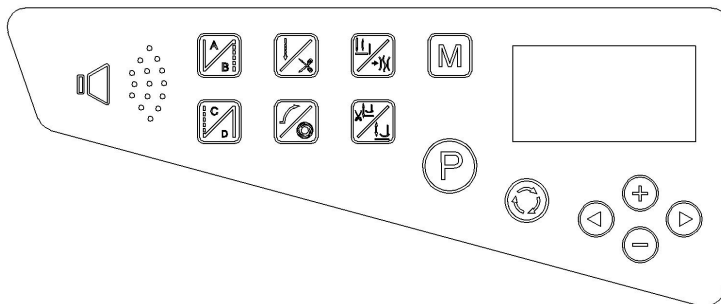















2、Functional introduction









2.1 Operation panel

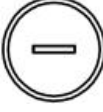

2.2 操作按键说明

Function	Button	The instructions of lockstitch Sewing motions
The selection of front straight line bar-tacking		Press choose front straight line bar-tacking (A,B sections) once, shown on the screen; press again choose front straight line bar-tacking (A,B sections) twice, shown on the screen; press one more time ,cancel front straight line bar-tacking Parameter interface can be used as a parameter up key.
The selection of back straight line bar-tacking		Press choose back straight line bar-tacking (C,D sections) once, shown on the screen; press again choose back straight line bar-tacking (C,D sections) twice, shown on the screen; press one more time, cancel back straight line bar-tacking. Parameter interface can be used as a parameter down key.
Thread clamp/The position of needle stop(up/down)		Press ,shown on the screen, the needle stop in the up position; Press ,shown nothing on the screen, the needle stop in the down position. Long press ,shown on the screen; Long press again for cancel, shown nothing on the screen.
Sewing mode selection		Press can choose free sewing; stitch quantity sewing; multi-section sewing and continuously reverse sewing 4mode.

<p>Free sewing/Thread trimming</p>		<p>Press  choose free sewing, shown  on the screen, mean already in the free sewing.</p> <p>1) The machine sew regularly when the pedal is stepped forward, it stops sewing when the pedal is back to middle position.</p> <p>2) The machine finishes thread trimming and thread sweeping automatically when the pedal is stepped towards back.</p> <hr/> <p>Long press  choose thread trimming auto, shown  on the screen, Long press  again for cancel, shown nothing on the screen.</p>
<p>Slow start/ Auto start</p>		<p>Press  for slow start ,shown  on the screen, press  again for cancel, shown nothing on the screen.</p> <p>1) When the function turned on, when the motor start the machine will execute the slow start stitch before regularly sew. It will only sew regularly when it's pressed forward again after stopping in the middle, unless the pedal is stepped towards back and then stepped forward ,the motor will execute slow start before running.</p> <p>2) The speed of the slow start setting can adjust by parameter[6]</p> <p>3) The No. of stitches of the slow start can adjust by parameter[7]</p> <hr/> <p>Long press  for auto start, show  on the screen, long press  again for cancel, shown nothing on the screen.</p> <p>In the stitch quantity sewing press the key:</p> <p>a. When the pedal is stepped forward, it will execute the setting stitch in the E,F or G,H sections, the AUTO will stop automatically when all the stitch in the sections are finished.</p> <p>b. Then touch the pedal one by one ,the machine will execute the next section's stitch until to finish the thread trimming and thread sweeping.</p>
<p>Auto foot lifter after thread trimming/Auto foot lifter when stop in the sewing</p>		<p>Press  choose auto foot lifter after thread trimming, show  on the screen, Press  again for cancel, shown nothing on the screen.</p> <hr/> <p>Long press  choose auto foot lifter when stop in the sewing, show  on the screen, Long press  again for cancel, shown nothing on the screen.</p>

Enter operating model		Press the key for 2 seconds to enter into the user operating model Press the key for 2 seconds to enter into the user operating model and continue pressing for 2 seconds more to enter the technician model.
Parameter increment setting		Setting the No. of stitches in A, B, C, D areas increment. The number can be set from 0 to F. Setting the No. of stitches in E, F, G, H areas increment. The number can be set from 0 to 99. Within Parameters in chosen area, the key has increase function. Within Parameters in setting area, the key has increment function. Within Parameters in sewing area, the key has speed-up function.
Number decreasing setting		Setting the No. of stitches in A, B, C, D areas decreasing, the number can be set from 0 to F. Setting the No. of stitches in E, F, G, H areas decreasing. The number can be set from 0 to 99. Within Parameters in chosen area, the key has decrease function. Within Parameters in setting area, the key has decrease function. Within Parameters in sewing area, the key has speed-down function.
Move to the Left		In A, B, C, D areas and E,F,G,H areas, move to the left. Parameter interface can be used as a parameter up key.
Move to the Right		In A, B, C, D areas and E,F,G,H areas, move to the right. Parameter interface can be used as a parameter down key.
Number of Stitch setting selection		For A,B,C,D four sections, the No. of stitches can be set from 0 -F (Note) For E,F,G,H four sections, the No. of stitches can be set from 0-99. <div style="display: flex; align-items: center; margin-bottom: 10px;"> <div style="margin-right: 10px;"></div> <div style="border: 1px solid black; padding: 5px; display: flex; gap: 10px;"> ABCD 4444 </div> <div style="margin-left: 10px;">.....Means A=B=C=D=4 stitch</div> </div> <div style="display: flex; align-items: center; margin-bottom: 10px;"> <div style="margin-right: 10px;"></div> <div style="border: 1px solid black; padding: 5px; display: flex; gap: 10px;"> EF 15 </div> <div style="margin-left: 10px;">.....means E=15stitch</div> </div> <div style="display: flex; justify-content: space-around; margin-top: 10px;"> GH </div>



1

1

5

.....mean G=1section H=15stitch

Press can choose to switch the up sections A,B,C,D, middle sections E,F, below sections G,H's No. of stitches setting and windows show. After changing the parameter, please press the key to reserve.

2.3 Key operation rules

- 1) Speed adjustment: In normal mode press , enter the speed parameter adjustment interface, Press again, increase at 50 each time, Long press , increase faster, wait for 3s to return to the main interface; In normal mode press , enter the speed parameter adjustment interface, Press again, decrease at 50 each time, Long press , increase faster, wait for 3s to return to the main interface. (Note)
- 2) Parameter adjustment: Long press for 2s to enter the parameter adjustment interface, press or to choose the parameter that need to change. Then press to change parameter data, the number in the screen will flicker. Press or to choose the data. Press or to change the data. And press to save and long press for 2s to exit this parameter adjustment interface.
- 3) Language change: Press , same time click key , will make sounds like “tick tock ” “tick tock-tick tock” “tick tock -tick tock-tick tock ”, sounds are as follows :No voice Chinese, English;
- 4) Volume control: Long press , meanwhile press to increasing volume.
- 5) The finished number Display: Long press to read the number.
- 6) he finished number Reset: Long press , and press to reset the number.
- 7) Needle stop position correction: Long Press and at the same time.
- 8) Reset the control parameters: Long Press , and then press . The control parameter will reset to factory setting.
- 9) Keyboard Reset: Long press , and then press . Keyboard work will reset to factory setting.
- 10) current state: Long press Read the current electric control, motor and other parameters.
- 11) Turn on/off the foot lifter: press and turn on/off the foot lifter.
- 12) Manual locking screen: Press , same time press to lock screen; In the lock screen state, long press to clear.
- 13) Automatic lock screen time setting: Long press into current state, press or to choose parameter “EM”, press or to revise lock screen time.
- 14) Backlight brightness adjusting: Long press into current state, press or to choose parameter “FM”, press or to adjust brightness.

Note:

1. The normal interface no have data flicker.
2. The meaning of A, B, C and D in the stitch selection box : A=10, B=11, C=12, D=13, E=14, F=15.

3、Function parameter list

3.1 A function parameter list

Parameter code	Corresponding content	range	Factory setting	Content instruction and memo
001. H	the highest rotational speed r/min	150~5000	3500	The setting of the lockstitch sewing highest speed is related to the machine
002. PSL	the adjustment of acceleration curve%	1~100%	90%	The setting of the controller climbing slope.
003. NUD	The options of stop needle position	UP/DN	DN	UP(Up stop-needle)/DN(down stop-needle)
004. N	Starting reverse sewing speed r/min	150~2800	1800	The setting of starting reverse sewing speed
005. V	Stopping reverse sewing speed r/min	150~2800	1800	The setting of stopping reverse sewing speed
006. B	Continuously reverse sewing speed r/min	150~2800	1800	The setting of continuously reverse sewing speed
007. S	Slow starting sewing speed r/min	150~2800	800	The setting of slow starting sewing
008. SLS	Slow starting sewing stitch number(stitch)	0~99 针	2	The stitch setting of slow starting sewing
009. A	Auto stitch quantity sewing speed r/min	300~5000	3000	The operation panel box AUTO key has the speed setting under pressing.
010. ACD	Automatic execute the function of stopping reverse sewing after stitch quantity sewing (Setting the function of un-compensate stitch)	OFF/ON	ON	ON: After executing the last setting stitch sewing, it will stop the reverse sewing automatically. Even in any sewing modes, it can not compensate stitch before stopping reverse sewing. OFF: After executing the last setting stitch sewing, it will not stop the reverse sewing automatically. It must restart, and it can compensate before stopping reverse sewing.

011. RVM	Manual reverse sewing function	JUK/BRO	JUK	The time that pressing the switch of the head reverse sewing: JUK: JUKI way (Even in the lockstitch sewing and stop, there are also actions) BRO: BROTHER way (Only in the lockstitch are there actions.)
012. SMS	The sport mode selection of starting reverse sewing	A/M	A	A:Step the pedal lightly and it will execute the stitch quantity sewing automatically. M:It can stop and start by controlling the foot pedal.
013. TYS	The operation mode selection after starting reverse sewing	CON/STP	CON	CON:After finishing the starting reverse sewing, it can continue sewing next function. STP:After finishing the starting reverse sewing, it will stop automatically.
014.SBT	Definition of dense stitch number	0~10	2	Setting the dense stitch number before finish sewing 0: no dense stitch 1: one stitch 2: two stitch ... 10: ten stitch
015.SBA	Strength of clamp electromagnet	0~11	7	
016.BB	Retain			
017. SBN	Starting reverse sewing setting	1~4	2	Set the back and forth times of starting reverse sewing
018.BT1	Starting reverse sewing compensation 1	Advanced actions: 1~16	8	BT1,BT2 = 0 Invalid; BT1,BT2 = 1~16 ahead action(1/8,the unit is stitch);
019.BT2	Starting reverse sewing compensation 2	Delay: 17~31	6	BT1,BT2 = 17~31 delay action (1/8,the unit is stitch);
020. SME	The sport mode selection of the stopping reverse sewing	A/M	A	A:Step the pedal lightly and it will operate the setting sewing automatically. M:It can stop and start by controlling the foot pedal.
021.CS	Retain			

022.EBC	Retain			
023.EBD	Retain			
024. EBN	Stopping reverse sewing setting	1~4	2	Set the back and forth times of the stopping reverse sewing
025.BT3	Stopping reverse sewing setting 3	Advanced actions: 1~8	6	BT3,BT4 = 0 Invalid; BT3,BT4 = 1~16 ahead action; BT3,BT4 = 17~31 delay action ;
026.BT4	Stopping reverse sewing setting 4	Delay: 9~15	8	
027.CT	Retain			
028.PNS	Retain			
029.DS	Retain			
030. BCC	Oil level alarm switch	0~1	1	0: Shut down alarm function for engine oil shortage. 1: Opening engine oil alarm function
031.SMB	Retain			
032.BAR	Retain			
033. BRC	dense stitch , action angle of electromagnet for dense stitch before cutting	0~359	0	action angle of electromagnet for dense stitch (The starting point of the needle is the seam angle of the electromagnet), The smaller the angle, the earlier the electromagnet action time.
034. PZO	Retain			
035. BT5	Continuously reverse sewing compensation 5	Advanced actions: 1~16	8	BT5, BT6 = 0 Invalid; BT5, BT6 = 1~16 ahead action; BT5, BT6 = 17~31 delay action ;
036. BT6	Continuously reverse sewing compensation 6	Delay: 17~31	6	
037. SMP	The sport mode selection of the setting sewing	A/M	M	A: Step the pedal lightly and it will execute the setting sewing automatically. M :It can stop and start by controlling the foot pedal.

038. PM	Retain			
039. PS	The compensation stitch function of the reverse sewing button	0/1	0	011.RVM is valid at the mode of BRO; OFF: The reverse sewing button can't be regarded as the function of the compensation stitch; ON: The reverse sewing button can be regarded as the function of the compensation stitch;
040. WON	Sweep line/grasp line output function setting	0~6	3	0:Don't have the action of sweeping line and grasping line 1:Have the action of sweeping line and don't have the action of grasping line 2:Don't have the action of sweeping line and have the action of grasping line(When the machine start, the angle is in the control of 071.W1、072.W2) 3: Have the action of sweeping line and grasping line.
041. TM	Unit statistics/The setting of bottom line count	0/1/10/100	0	0—The mode of the number statistics, it increases according to the quantity of processing; Not 0—The mode of the number statistics, it decreases according to the quantity of processing 1—The cardinal number 1 decrease 10—The cardinal number 10 decrease 100—The cardinal number 100 decrease
042. PSM	When it stops during the lockstitch sewing, and select the presser foot output.	OFF/ON	ON	OFF: It means to cancel the function of the foot lift.
043. FTM	When trimming stops ,and select the presser foot output.	OFF/ON	ON	OFF: It means to cancel the function of the foot lift.
044. PN	The finished number of lockstitch sewing	0~9999	0	Setting according to 041.PBS parameter, it will show the finished number or the number of bottom line

045. SSS	The selection of slow starting sewing	OFF/ON	OFF	FF: It means to eliminate the function of slow start sewing.
----------	---------------------------------------	--------	-----	--

3.2 B function parameter list

Parameter code	Corresponding content	range	Factory setting	Content instruction and memo
046. DIR	The motor running direction setting	CW/CCW	CW	CCW: counter-clockwise CW: clockwise
047. MAC	The style of sewing machine	0~256	6	The style set of the sewing machine. Less than 80, it is the lockstitch sewing. 9: Special lockstitch sewing has a slow start stitch. At the situation of slow start, the first stitch of free sewing is always slow.
048. SYM	The style setting of synchronous machine	0~3	3	0:H is synchronous machine, and it is compatible to HOHSING 1:B is modified synchronous machine. Up needle position, down needle position, self-check signal line 2:D is synchronous machine with direct drive DB9 installed electric self-check signal line without synchronous machine. Up needle position, down needle position, and encode signal. 3:S is synchronous machine, it only has zero signal, up needle position and down needle position that need 076.DRU and 078.URU to set the angle of needle position.
049. SPD	The size of the head pulley	30~200	35	The front pulley size is set along with the head model code.
050. MPD	The size of the motor belt	50~150	75	The front pulley size is set along with the head model code.

051. CHK	Whether power-on self-test function turn on or not. (the foot pedal signal, power-off detection)	0~10	1	1:Power-on self-test function turn on 0:Power-on self-test function turn off The setting of extended feature: Judging the time by locked machine. 0 means 10 seconds. 1 means 2 seconds. 2 means 3 seconds. 9 means 10 seconds.
052. PA	Front foot pedal sewing speed react the sensitivity settings.	50—400%	70%	5% of the pedal speed react the slowest speed, 400% of the pedal speed react the pedal the quickest speed, according to the operator proficiency to set.
053. FT	Half step backward presser foot in the process of sewing (step lightly backward presser foot) to confirm the time.	50~2000ms	100	If installing the foot lift, please according to the sewing machine pedal flexibility to set the parameters.
054. BK	When the motor stop, the brake can lock automatically.	OFF/ON	OFF	ON:When the motor stop, the brake can lock the head. OFF:No effect.
055. TOT	When UTD is ON, it means the limit time of motor running.	1~800Hrs	8	The longest time is 33 days(800 hours)
056. TM1	When UTD is ON , it means the motor running time.	1~60s	2	When operating test automatically, it means the working hours of free sewing.
057. TM2	When UTD is ON, it means the motor stopping time	1~60s	51	When operating test automatically, each interval time. Code over 50,foot lift shown soft down function
058. UTD	The function of automatic operation test	OFF/ON	OFF	When the parameter is ON, the automatic operation test start and run according to the elected stitch

				sewing pattern box to set.
059. T	The speed setting of trimming and stopping r/min	120~400	300	The speed adjustment of trimming parking, the speed is too low that may lead to abnormal trimming. The speed is too high that may lead to an unstable position control.
060. L	Low speed r/min	120~400	200	The speed adjustment of operating slowly
061. FO	the full initial output time of presser foot, reverse sewing /ms	0~990	250	When presser foot and reverse sewing start, the time of the full output.
062. FC	The cycle signal of presser foot and reverse sewing /%	10~90	30	When presser foot and reverse sewing operate, the power output periodically to avoid the presser foot hot
063. FD	Delay the motor start to protect the time of the presser foot put down.	0~990	150	When stepping, delay the machine start to match the confirmation of presser foot.
064. HHC	Half-step pedal to cancel the presser foot function	OFF/ON	OFF	ON:When half-step pedal, it doesn' t have the output of lifting pedal and direct trimming. OFF:When half-step step, it has the output of lifting pedal and don' t trim (Trimming only full-step pedal)
065. SFM	Safety switch signal form	0/2	0	0:When the safety switch input signal ,it must remain open state; 2:When the safety switch input signal, it must remain normally close.
066. LTM	Trimming time-series mode	0/1/2/3	2	0: retain 1: retain 2:Bottom positioning cut to up positioning trimming mode (lockstitch sewing trimming mode) 3:Interlock sewing trimming mode (the stop cut)
067. T1	The angle of loosing grab thread (Up needle position is 0°)	0~990	110	From up needle position delay few time angle loose the grab thread electromagnet.If setting 10,it means up position 10° loose the electromagnet.

068. T2	Catching the continuous angle of the action of the wire magnet (mechanical angle)	0~990	240	The angle of the working experience of a wire catching electromagnet. (mechanical angle), That is to turn from T1 to (T1+T2) angle, where (067.T1+068.T2) must be about 076.DRU
069. M	The speed setting of midway parking	150~1000	950	The speed setting of midway no-parking trimming.
070. NC	After trimming parking, the angle setting of reverse lifting needle	0~280	0	0: Do not need to lift the needle back. 1-280 the angle of reverse lifting needle, 4 represents one degree.
Sweep mode				
071. W1	Delay time before sweeping /ms	0~980	5	The interval time of sweeping after finding up-position.
072. W2	Sweeping time /ms	0~9990	50	Sweeping time
Grab line mode				
071. W1	Retain			
072. W2	The angle of loosing grab thread(down needle position is 0°)	0~360	50	From down needle position delay few time angle loose the grab thread electromagnet. If setting 10,it means down position 10°loose the electromagnet.
073. WF	Delay time before the presser foot /ms	0~990	30	The interval time of entering into the foot lift after sweeping
074. FHT	when sewing stops, automatic presser foot rise maintenance time/s	1~200	30	Automatic presser foot rise maintenance time
075. UEG	The adjustment of the up-needle stop position	5~250	60	Modify lightly the angle position of the up-needle stop (the center number is 40): It will lift the needle stop in advance when the number decreases. It will delay the needle stop when the number increasing.
076. DRU	From the down-needle position reverse rotation reaches the angle of the up-needle position	1~360	165	[048.SYM] set 3:00,from the down-needle reaches the up-needle reverse angle to set the virtual down-needle position.

077. ANU	After power-on, automatically find the position	OFF/ON	ON	ON:After the power turn on, automatically find the positioning signal to stop OFF:No effect
078. URU	From the up-needle position, reverse rotation reaches zero angle	1~360	0	[048.SYM] set 3:00,from zero reaches to the reverse angle of up-needle positions set a virtual down-needle position
079. ERR	The error code of the last trouble	0~999	0	0—No trouble

4、Error code and the way to solve

Error code	Code Content	The possible problem	The way to solve	
F a a l e r o r	ERR—00	The self-test of input signals is wrong	<ol style="list-style-type: none"> The circuit of the pedal has a problem, or the pedal has been in forward riding, backward riding and can't return to the neutral position.; Safety switch signal 	<ol style="list-style-type: none"> Loose the pedal and return to the neutral position. Checking whether the signal line of the pedal insert or not.
	ERR—01	The head signal feedback is abnormal.	<ol style="list-style-type: none"> The synchronous machine is abnormal, and can not find the up-needle position; The sensor magnet is off.. 	
	PWROFF	Power-off	<ol style="list-style-type: none"> The 30v fuse is wrong. The system is power-off. 	Power-off and check each fuse and power on again.
	ERR—03	The operation of the head is abnormal./ Oil level alarm switch	<ol style="list-style-type: none"> The synchronous machine is abnormal, and can not find the up-needle position; The sensor magnet is off.; The oil level is below normal. 	Check whether the oil quantity is up to the normal value.
	ERR—04	Over-current, over-voltage, under-voltage	<ol style="list-style-type: none"> The motor power module is wrong; Immediately interrupt. 	
	ERR—05	DC voltage exceeds the voltage	<ol style="list-style-type: none"> The braking resistor is wrong or the braking fuse is broken. Immediately interrupt. 	Close the system power-supply and check

ERR—06	The solenoid power is over-current	1. The electromagnet is over-loaded or short circuit; 2. The driving circuit is wrong; 3. Immediately interrupt.	Close the system power-supply and check
ERR—07	Block	1. The machine is blocked; 2. The cutting-line system is wrong; 3. The encoder signal is abnormal.	Close the system power-supply and check whether the sewing machine' s mechanical features is normal or not.

After having a problem, firstly, shutting down the system supply, and then checking whether the control system connect ground or not. After 30 seconds, renew to start the power supply and checking whether the power supply work or not. If it still don't work, please try again. If the problem still eliminate, please contact the supplier.

5、Comparison table for script display on control box with the actual digital

The number style part:

Actual number	0	1	2	3	4	5	6	7	8	9
Display number	0	1	2	3	4	5	6	7	8	9

The English style part:

Actual alphabet	A	B	C	D	E	F	G	H	I	J
Display alphabet	A	b	C	d	E	F	G	H	i	J
Actual alphabet	K	L	M	N	O	P	Q	R	S	T
Display alphabet	k	L	n	n	o	P	q	r	S	r
Actual alphabet	U	V	W	X	Y	Z				
Display alphabet	U	u	W	W	Y	z				